

# TECNOTION<sup>®</sup>

THE LINEAR MOTOR COMPANY

*Frameless Torque Motor Series*



Email: [info@grp6.com](mailto:info@grp6.com) Tel: 800-433-3434 x110

# QUALITY AND SERVICE DELIVERED WORLDWIDE

## [ TECNOTION ]

Tecnotion is *the* global authority on direct drive motor technology. We are the world's only unbundled manufacturer of linear and torque motors. A former part of Philips, we specialize solely in the development and production of linear and torque motors. Because of this, our expertise, customer service and product quality are unmatched.

We have a global presence, with production plants in The Netherlands and China and local representation around the world. This ensures short delivery times and high quality support, wherever you are located.

When you do business with Tecnotion, you have a team of highly skilled sales and application engineers at your disposal. They help you from your initial prototype all the way to the application of our products and beyond.

Whatever your needs, you can rely on Tecnotion as a solid, reliable partner.



Email: [info@grp6.com](mailto:info@grp6.com) Tel: 800-433-3434 x110



## [ SALES SUPPORT ]

At Tecnotion we understand that each application of our motors is a unique case with specific requirements and demands.

Our sales and application engineers have extensive experience with a wide range of application types and collaborate on a high level with our customers to make sure you get the solution that best fits your requirements.

Additionally our specialized Simulation Tool is available to help you find your way through our wide range of motors and analyze/test out different motor types within your application specifications.

## [ INNOVATION ]

We have an in-house R&D department, which is continuously pushing the boundaries of technology and taking our products to the next level. This translates directly to our high level of understanding of manufacturing processes.

Apart from our "off-the-shelf" range of standard motors, we can also design and manufacture custom made motors for high profile projects or OEM applications that require a tailor-made solution.

All our custom motors are built to the same high standards that characterize our standard range of products.



## [ MANUFACTURING ]

Manufacturing of our standard range of motors takes place at our modern plant in China, where we are able to produce in high volume at very competitive rates.

At our competence centre and headquarters in The Netherlands we specialize in advanced technology. This is where we do our research and development and where custom motors are built with extreme accuracy in our special state of the art clean room environment.

Tecnotion is committed to excellence. Both of our plants are ISO 9001 certified and comply to the highest quality standards possible.

## [ GLOBAL LOGISTICS ]

We always have our most popular products in stock in our warehouses in both The Netherlands and China.

Our logistics department can ship to you from both locations, making short delivery times possible across the globe, even when markets are ramping.



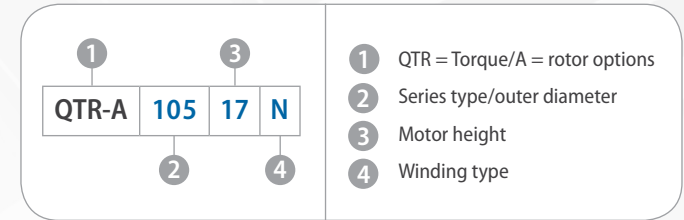

### QTR-A 65 Series

*Tp 0.39..3.67Nm Tc 0.27.. 2.32Nm*

The QTR-A 65 is the smallest torque motor in the Tecnotion QTR range. This motor is optimized for small and low voltage applications. The 65 Series is available in four motor 'heights' or 'sizes', a 17, 25, 34 and 60 size motor.

Compact sizing and low voltage support make the 65 mm QTR motor ideal for robotics applications.



### QTR-A 78 Series

*Tp 0.8.. 7.5Nm Tc 0.55.. 4.75Nm*

The QTR-A 78 is the second size available in the Tecnotion QTR range. As with the 65 Series motor, the 78 series motor is optimized for low voltage applications with a small build-space available. The largest QTR-A 78-60 motor offers a peak torque of 7.5Nm.

Small build-space and a large 29mm inner diameter make the QTR 78 motor a favorite in semiconductor machinery.



### QTR-A 105 Series

*Tp 1.9..18Nm Tc 1.4..12Nm*

The QTR-A 105 is where the medium-range of Tecnotion QTR motors starts. QTR-A 105 motors are available with a wide range of options such as different winding types and a digital hall sensor.

Various medical and health care applications benefit from the large inner diameter of the QTR 105 as well as the flat designs, starting at just 17 mm.



### QTR-A 133 Series

*Tp 3.7..35.3Nm Tc 2.6..21.9Nm*

The QTR-A 133 is the second medium-range QTR motor. It covers the torque range from 2.6 to 21.9Nm. The largest 60 mm high QTR-A-133-60 motor offers a peak torque of over 35.3Nm. Different winding types are available, optimizing Back EMF. High peak force make the QTR 133 Series ideal for usage in testing equipment.



### QTR-A 160 series

*Tp 6.2..58.3Nm Tc 4.1..36.3Nm*

The QTR-A 160 series is the largest in diameter of the QTR motor range. The smallest motor measures just 17 mm in height, the largest motor excels with a 58.3 Nm peak torque. Power and size make that the QTR 160 Series motors can often replace large factory machinery. They are the best choice when implementing factory automation to the fullest.

# Frameless torque motors

## Overview of the complete range

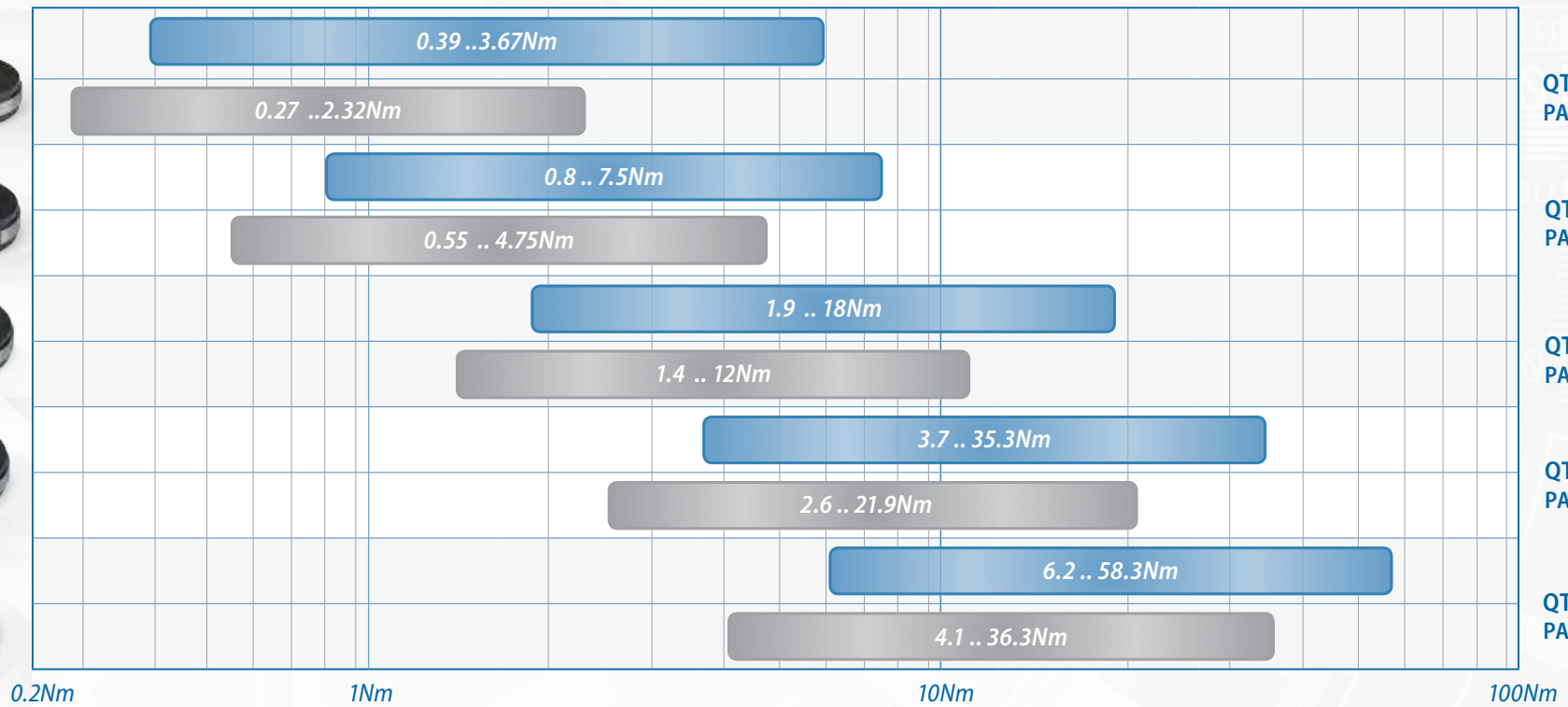

Peak torque
  Continuous torque

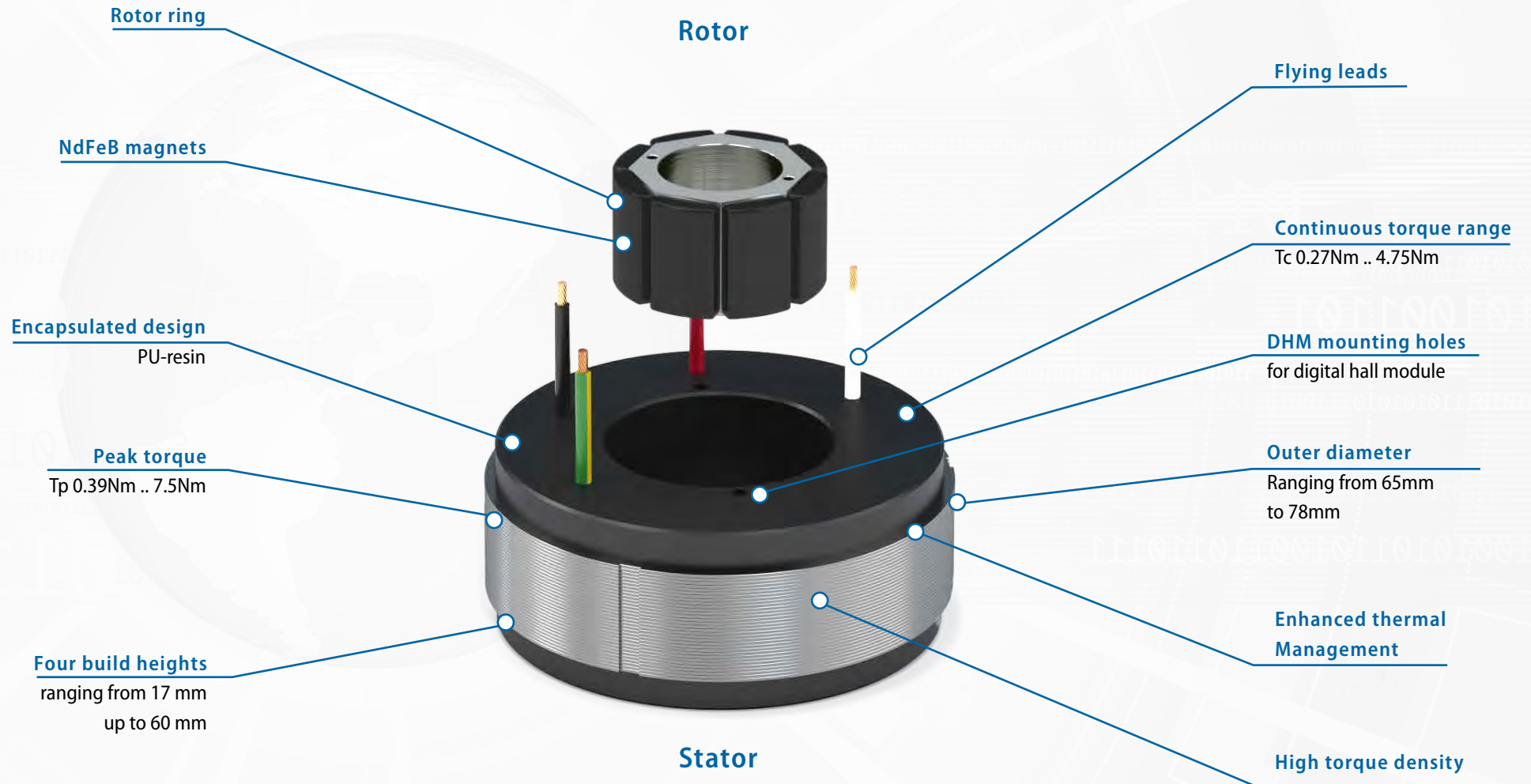

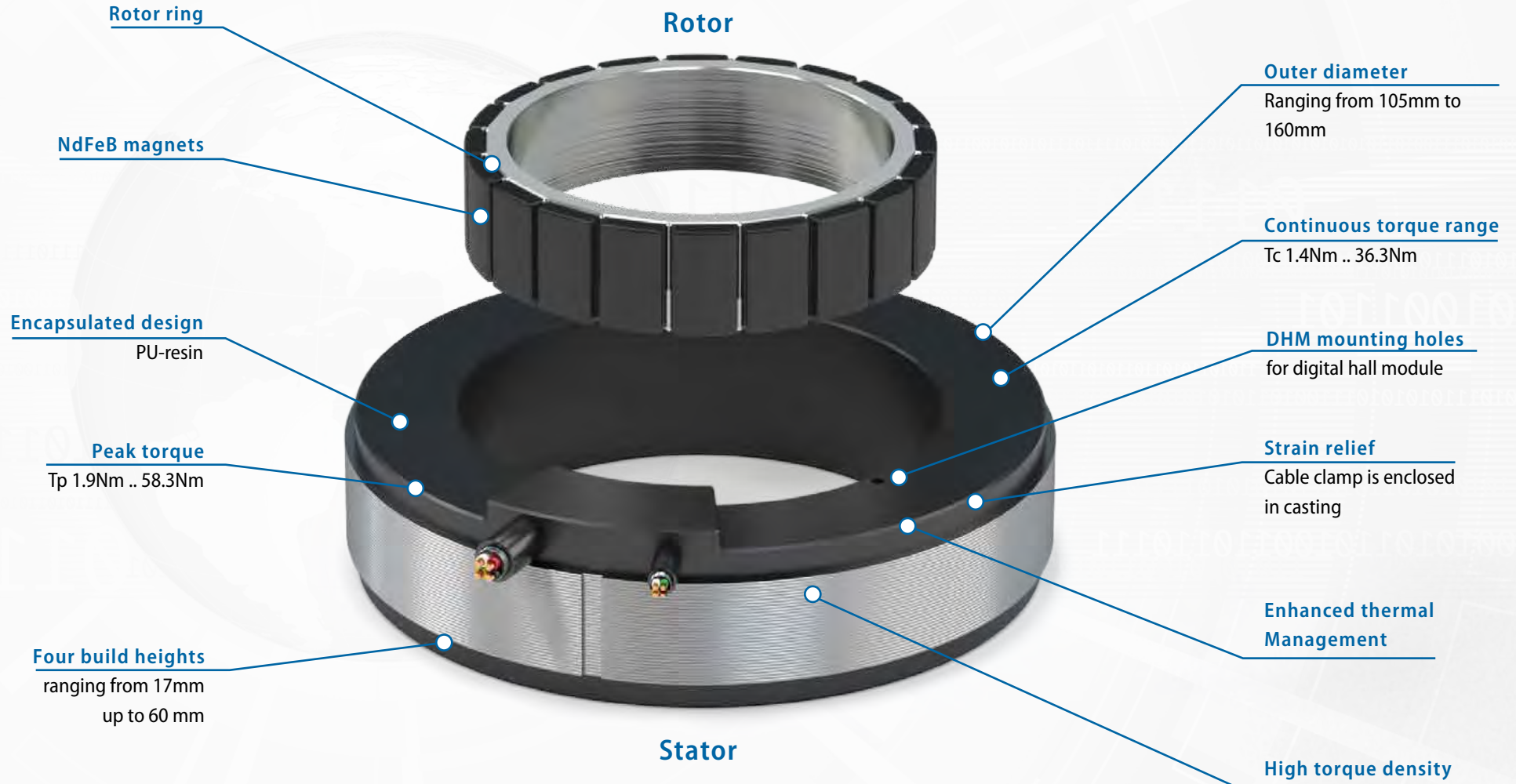

# Features

## Tecnotion's QTR torque motor performance advantages

The direct drive technology of brushless torque motors is a perfect way to enhance productivity, accuracy, and dynamic performance of applications. The technology lowers costs, makes designs slimmer, and reduce wear and tear. Torque motors eliminate the need for mechanical transmissions like gearboxes, belts and speed reducers. Between rotor and stator there is no contact, this means no mechanical wear.

**Direct drive**  
Higher stiffness no backlash.

**Ultra thin design**  
The lower build height allows to build flatter axis, resulting in less tipping and settling time. Extraordinary flexibility in designing the motor in to small spaces.

**Tecnotion QTR has the highest torque density in the market**  
More torque in a smaller packing means lowering footprint.

**Low thermal resistance**  
Allowing good heat transfer, achieving an extremely high continuous torque when using a descent size heatsink or active cooling.

**Low cogging value , low total harmonic distortion THD**  
For smooth motion and position accuracy in your application.

**Encapsulated design**  
No open coil wires which can be damaged or that need to be covered up for safety reasons.

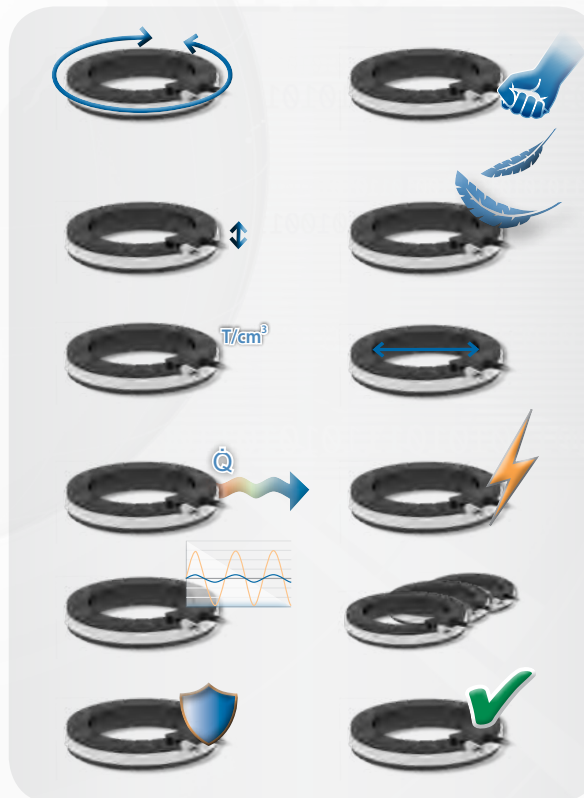

**Shielded cable with strain relief**

No shielding EMC issues with loose wires. No risk to damage the motor by accidentally pulling the cable.

**Low stator and rotor mass**

Lower masses increase the dynamics and response of the system by lowering the inertia. It hands the opportunity to improve entire stage designs! And as a result, lowering an applications cost of ownership.

**Large inner diameter**

Allows easy integration of a large number of cables and hoses or allows large shaft fittings.

**High voltage insulated, up to 300VDC/600VDC busvoltage**

Enabling the use of a wide range of servo drives, and power supplies.

**Good product repeatability**

All motors have specifications with extremely little variation between them.

**100% QC**

All products are 100% mechanically and electrically tested.



## Torque QTR-A Digital hall module

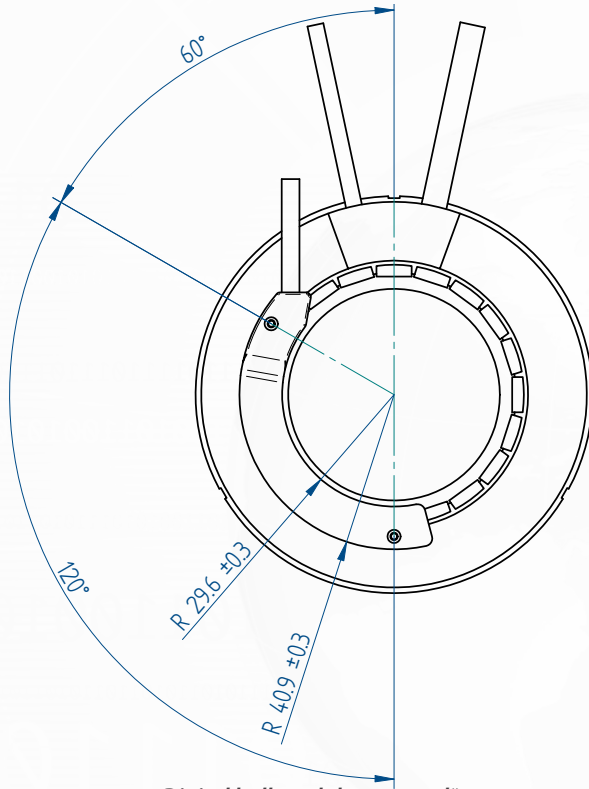

Digital hall module mounted\* on  
QTR-A 105 Series

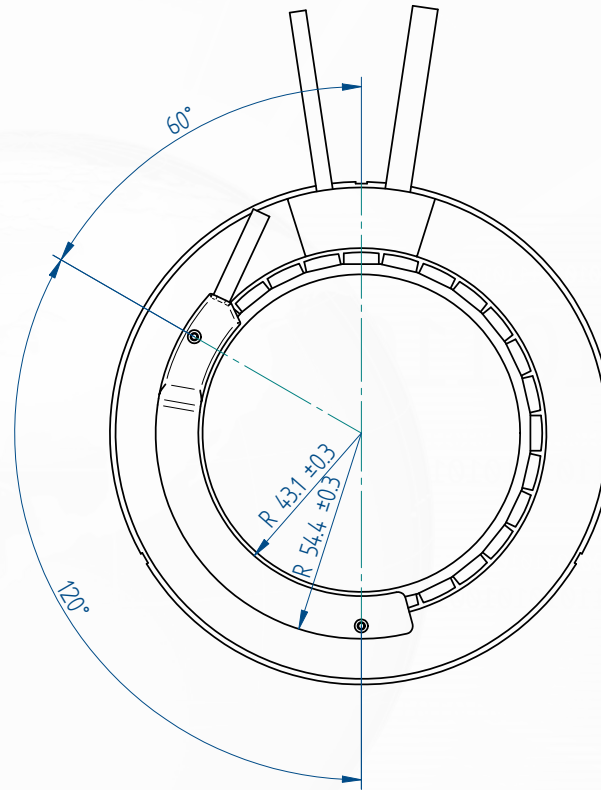

Digital hall module mounted\* on  
QTR-A 133 Series

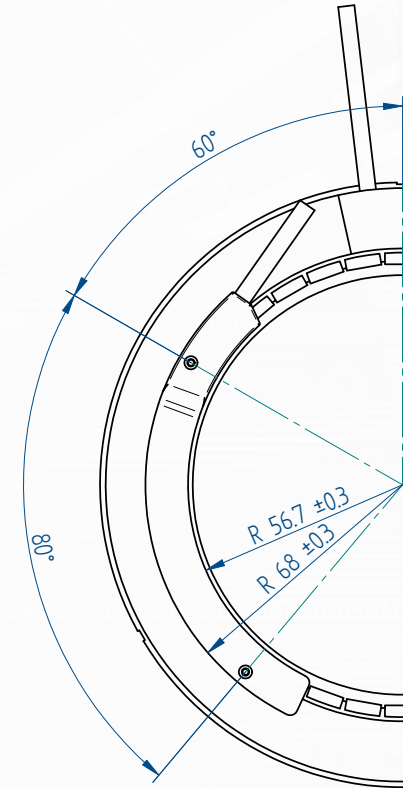

Digital hall module mounted\* on  
QTR-A 160 Series

### Specifications

Input voltage:	+6...15Vdc
Output voltage:	3 phase TTL, max 2.5mA, 5Vdc AquadB TTL, max 2.5mA, 5Vdc

\* Mounting instructions and tolerances can be found in the Torque installation manual. Manuals and 3D CAD files can be downloaded from our website.



QTR Digital hall module

Tecnotion QTR motors can be equipped with a Tecnotion QTR digital hall module. The module covers a small portion of the motor and measures just a little over 3 mm in thickness for the largest part. When a QTR stator is not powered the Tecnotion QTR Digital Hall sensor can be used to determine the electrical position of the rotor. It is a 'wake and shake' replacement, simplifying the startup of the QTR motor. Digital Hall sensors are available for all diameters of the Tecnotion QTR motor range.



Mounting instructions and tolerances can be found in the Torque installation manual. Manuals and 3D CAD files can be downloaded from our website.

## STATOR

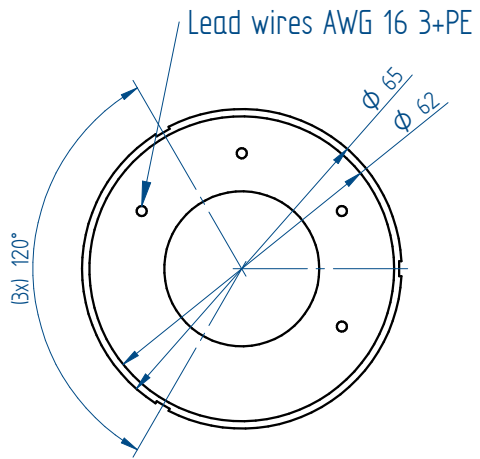

QTR 65-17

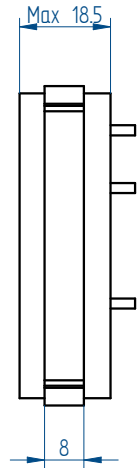

QTR 65-25

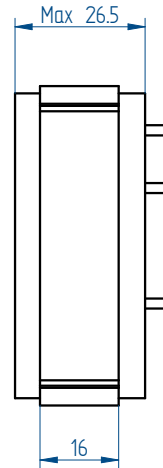

QTR 65-34

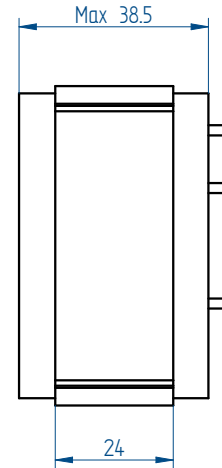

QTR 65-60

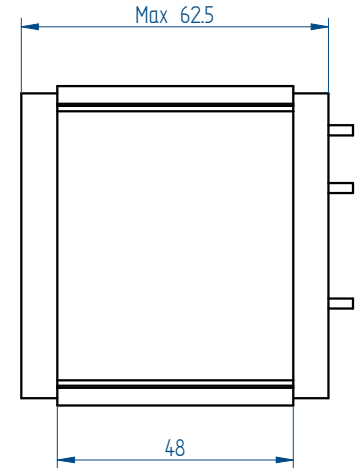

## ROTOR

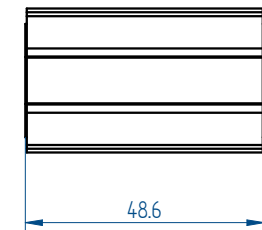
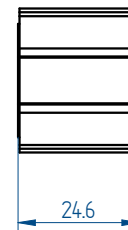
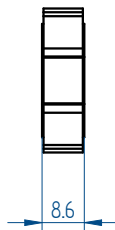
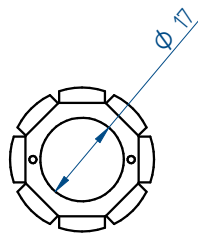

\* All sizes are in mm

	Parameter	Remarks	Symbol	Unit	QTR-A 65-17	QTR-A 65-25	QTR-A 65-34	QTR-A 65-60
Performance	Winding type				N	N	Y	Y
	Motor type, max voltage ph-ph	3-Phase synchronous		$V_{acrms} (V_{ac})$	420 (600)			
	Ultimate Torque @ 20°C/s increase	magnet @ 25°C	$T_u$	Nm	0.64	1.27	2.21	5.98
	Peak Torque @ 6°C/s increase	magnet @ 25°C	$T_p$	Nm	0.39	0.78	1.37	3.67
	Continuous Torque	coil@100°C	$T_c$	Nm	0.27	0.62	1.05	2.32
	Maximum speed <sup>(1)(4)</sup>	@Tc @ 48 Vdc	$n_{max}$	rpm	6200	3000	3800	1070
	Motor Torque constant	up to Ic	$K_t$	Nm/A <sub>rms</sub>	0.058	0.115	0.097	0.291
	Motor constant	coils @ 25°C	$K_m$	(Nm) <sup>2</sup> /W	0.0020	0.0057	0.0119	0.0373
Electrical	Ultimate Current	magnet @ 70°C	$I_u$	A <sub>rms</sub>	13.80	13.80	28.50	25.70
	Peak Current	magnet @ 25°C	$I_p$	A <sub>rms</sub>	7.56	7.56	15.66	14.04
	Maximum Continuous Current <sup>(2)</sup>	coils @ 100°C	$I_c$	A <sub>rms</sub>	4.64	5.34	10.82	7.98
	Back EMF Phase-Phase <sub>peak</sub>		$K_e$	V/krpm	4.9	9.9	8.3	24.8
	Back EMF Phase-Phase <sub>RMS</sub>		$K_e$	V/krpm	3.5	7.0	5.9	17.5
	Coil Resistance per Phase	coils @ 25°C ex. cable	R	Ω	0.55	0.77	0.26	0.80
	Coil induction per Phase	$l < 0.6 l_p$	L	mH	1.0	1.6	0.7	2.8
	Electrical Time Constant	coils @ 25°C	$\tau_e$	ms	1.9	2.1	2.6	3.7
Thermal	Poles		$N_{mgn}$	nr	8	8	8	8
	Continuous Power Loss	coils @ 100°C	$P_c$	W	46	86	120	188
	Thermal Resistance <sup>(3)</sup>	coils to mount. sfc.	$R_{th}$	°C/W	1.63	0.88	0.63	0.40
	Thermal Time Constant	Up to 63% max. coiltemp	$\tau_{th}$	s	22	17	17	41
Mechanical	Temperature Cut-off / Sensor				No temperature sensor			
	Stator OD		OD <sub>S</sub>	mm	65			
	Rotor ID		ID <sub>R</sub>	mm	17			
	Motor Height		H <sub>motor</sub>	mm	18	26	36	62
	Lamination Stack Height		H <sub>arm</sub>	mm	8	16	24	48
	Rotor Inertia		J <sub>R</sub>	kg*m <sup>2</sup>	3.8E-06	7.5E-06	1.1E-05	2.3E-05
	Stator Mass	ex. cables	M <sub>S</sub>	g	151	251	363	783
	Rotor Mass		M <sub>R</sub>	g	27	54	80	160
	Total Mass	ex. cables	M <sub>T</sub>	g	178	305	443	943
	Cable Mass	all cables	m	g	36			
Cable Type (Power)	length 0.5 m	d	mm (AWG)	2.06 (16)				



QTR-A-65 Stator and rotor shown with a height of 17 mm

1. Actual values depend on bus voltage. Please check the T/n diagram in our manual or online simulation tool.
2. These values are only applicable when the mounting surface is at 20°C and the motor is driven at maximum continuous current. If these values differ in your application, please check our simulation tool or manual.
3. R<sub>th</sub> based on radial mounting of stator lamination stack.
4. MAXIMUM allowable speed for QTR-A 65 Series motors is 28,000rpm. If you plan a high speed application, please contact Tecnotion.

All specifications ±10%

Mounting instructions and tolerances can be found in the Torque installation manual. Manuals and 3D CAD files can be downloaded from our website.

## STATOR

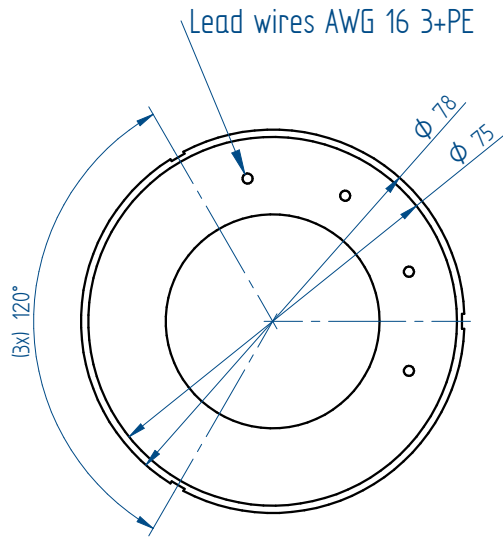

QTR 78-17

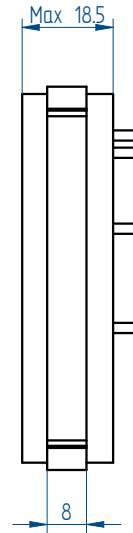

QTR 78-25

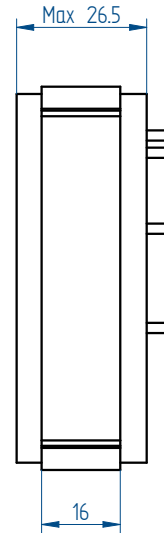

QTR 78-34

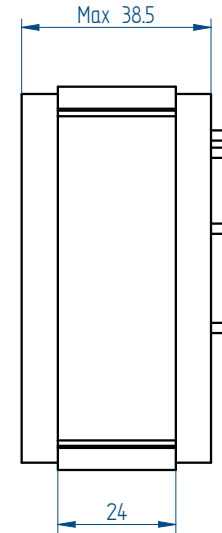

QTR 78-60

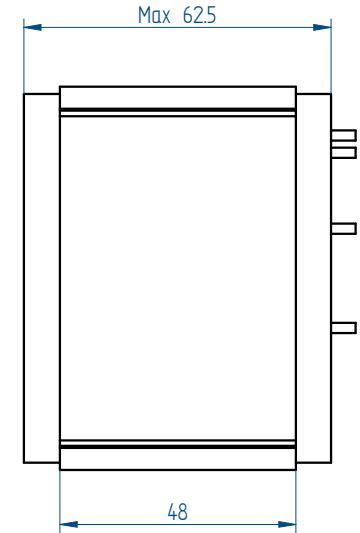

## ROTOR

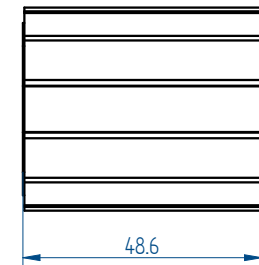
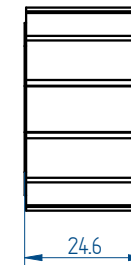
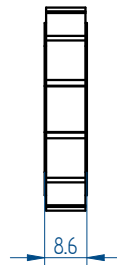
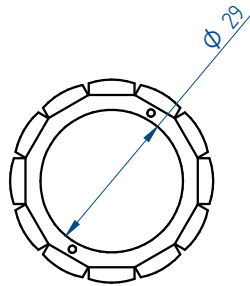

\* All sizes are in mm

	Parameter	Remarks	Symbol	Unit	QTR-A 78-17	QTR-A 78-25	QTR-A 78-34	QTR-A 78-60
Performance	Winding type				N	Y	Y	Y
	Motortype. max voltage ph-ph	3-Phase synchronous		$V_{acrms} (V_{dc})$	420 (600)			
	Ultimate Torque @ 20°C/s increase	magnet @ 25°C	$T_u$	Nm	1.31	2.61	4.52	12.23
	Peak Torque @ 6°C/s increase	magnet @ 25°C	$T_p$	Nm	0.80	1.61	2.79	7.52
	Continuous Torque	coil@100°C	$T_c$	Nm	0.55	1.26	2.15	4.75
	Maximum speed <sup>(1)(4)</sup>	@Tc @ 48 Vdc	$n_{max}$	rpm	2700	2620	1660	410
	Motor Torque constant	up to Ic	$K_t$	Nm/A <sub>rms</sub>	0.118	0.132	0.198	0.595
	Motor constant	coils @ 25°C	$K_m$	(Nm) <sup>2</sup> /W	0.0056	0.0160	0.0332	0.1042
Electrical	Ultimate Current	magnet @ 70°C	$I_u$	A <sub>rms</sub>	13.8	24.6	28.5	25.7
	Peak Current	magnet @ 25°C	$I_p$	A <sub>rms</sub>	7.56	13.50	15.66	14.04
	Maximum Continuous Current <sup>(2)</sup>	coils @ 100°C	$I_c$	A <sub>rms</sub>	4.64	9.54	10.80	8.00
	Back EMF Phase-Phase <sub>peak</sub>		$K_e$	V/krpm	10.1	11.3	17.0	50.9
	Back EMF Phase-Phase <sub>RMS</sub>		$K_e$	V/krpm	7.1	8.0	12.0	36.0
	Coil Resistance per Phase	coils @ 25°C ex. cable	R	Ω	0.83	0.36	0.39	1.10
	Coil induction per Phase	$l < 0.6 l_p$	L	mH	1.55	0.76	1.04	4.20
	Electrical Time Constant	coils @ 25°C	$\tau_e$	ms	1.9	2.1	2.6	3.7
Thermal	Poles		$N_{mgn}$	nr	12	12	12	12
	Continuous Power Loss	coils @ 100°C	$P_c$	W	69	129	180	281
	Thermal Resistance <sup>(3)</sup>	coils to mount. sfc.	$R_{th}$	°C/W	1.08	0.58	0.42	0.27
	Thermal Time Constant	Up to 63% max. coiltemp	$\tau_{th}$	s	22	17	17	41
Mechanical	Temperature Cut-off / Sensor				No temperature sensor			
	Stator OD		OD <sub>S</sub>	mm	78			
	Rotor ID		ID <sub>R</sub>	mm	27			
	Motor Height		H <sub>motor</sub>	mm	18	26	36	62
	Lamination Stack Height		H <sub>arm</sub>	mm	8	16	24	48
	Rotor Inertia		$J_R$	kg*m <sup>2</sup>	1.3E-05	2.5E-05	3.8E-05	7.6E-05
	Stator Mass	ex. cables	$M_S$	g	212	350	505	1115
	Rotor Mass		$M_R$	g	42	84	126	243
	Total Mass	ex. cables	$M_T$	g	254	434	631	1358
	Cable Mass	all cables	m	g	36			
Cable Type (Power)	length 0.5 m	d	mm (AWG)	2.06 (16)				

All specifications ±10%



QTR-A-65 Stator and rotor shown with a height of 17 mm

1. Actual values depend on bus voltage. Please check the T/n diagram in our manual or online simulation tool.
2. These values are only applicable when the mounting surface is at 20°C and the motor is driven at maximum continuous current. If these values differ in your application, please check our simulation tool or manual.
3. R<sub>th</sub> based on a radial mounting of stator lamination stack.
4. MAXIMUM allowable speed for QTR-A 65 Series motors is 23.000 rpm. If you plan a high speed application, please contact Tecnotion.

Mounting instructions and tolerances can be found in the Torque installation manual. Manuals and 3D CAD files can be downloaded from our website.

## STATOR

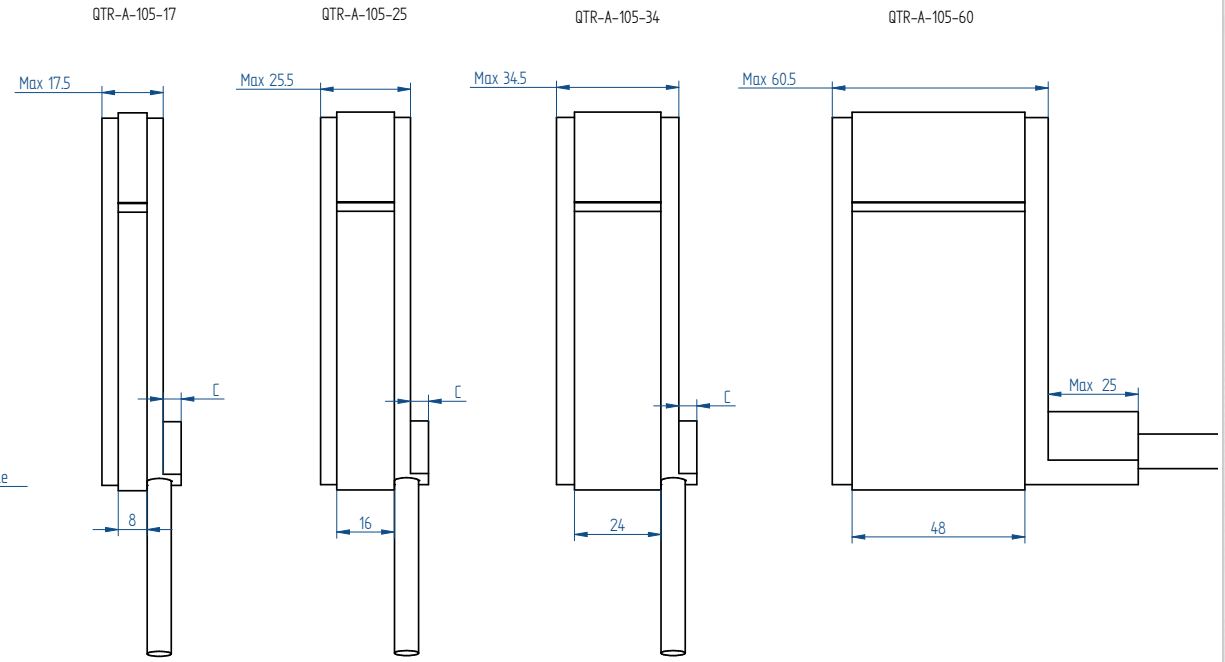
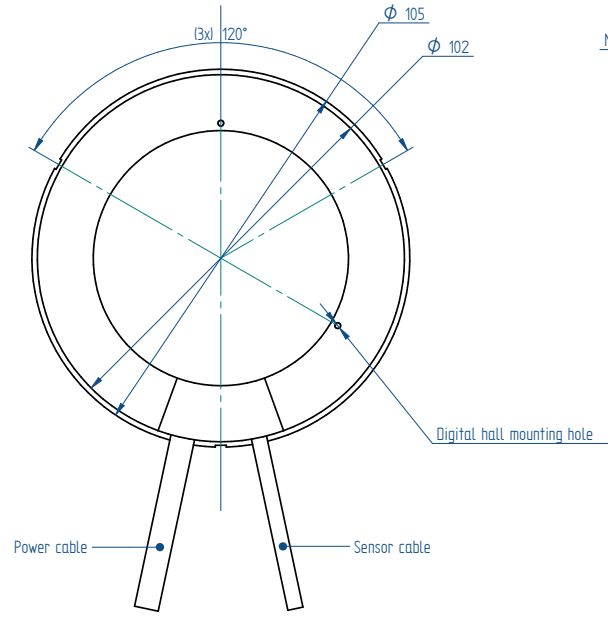

## ROTOR

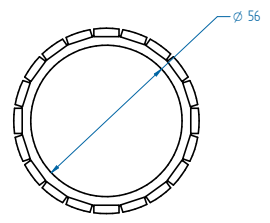

\* All sizes are in mm

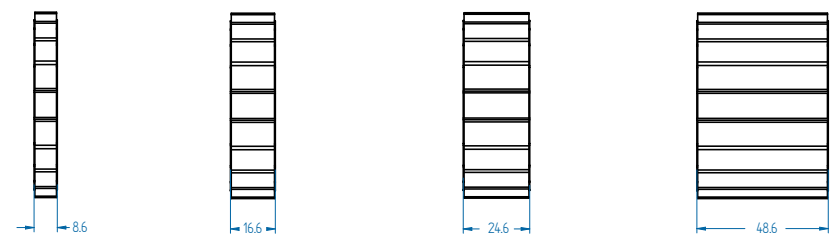

winding	C (mm)
N	3.5
Y+Z	5.5

Parameter	Remarks	Symbol	Unit	QTR-A-105-17			QTR-A-105-25			QTR-A-105-34			QTR-A-105-60
				N	Y	Z	N	Y	Z	N	Y	Z	N
Winding type				N	Y	Z	N	Y	Z	N	Y	Z	N
Motor type, max voltage ph-ph	3-Phase synchronous		$V_{acrms} (V_{dc})$	230 (300)									420 (600)
Ultimate Torque @ 20°C/s increase	magnet @ 25°C	$T_u$	Nm	2.9	3.3	3.3	6.1	7.5	6.9	10.6	11.3	10.4	28.4
Peak Torque @ 6°C/s increase	magnet @ 25°C	$T_p$	Nm	1.9	2.2	2.2	3.9	4.4	4.4	6.7	6.6	6.6	18.1
Continuous Torque	coil @ 100°C	$T_c$	Nm	1.4	1.4	1.4	3.2	3.3	3.3	5.4	5.2	5.2	12.0
Maximum speed <sup>(1)(4)(5)</sup>	@Tc	$n_{max}$	rpm	6918	1629	3156	3579	757	1569	1866	412	980	1386
Motor Torque constant	up to Ic	$K_t$	Nm/A <sub>rms</sub>	0.30	0.17	0.10	0.60	0.33	0.19	1.07	0.50	0.29	2.86
Motor constant	coils @ 25°C	$K_m$	(Nm) <sup>2</sup> /W	0.021	0.022	0.022	0.061	0.065	0.065	0.127	0.115	0.120	0.40
Ultimate Current	magnet @ 70°C	$I_u$	A <sub>rms</sub>	13.8	28.2	48.8	13.8	28.2	48.8	13.3	28.2	48.8	13.5
Peak Current	magnet @ 25°C	$I_p$	A <sub>rms</sub>	7.6	15.4	26.7	7.6	15.4	26.7	7.3	15.4	26.7	7.37
Maximum Continuous Current <sup>(2)</sup>	coils @ 100°C	$I_c$	A <sub>rms</sub>	4.6	8.5	14.7	5.3	9.8	17.0	5.1	10.3	17.9	4.2
Back EMF Phase-Phase <sub>peak</sub>		$K_e$	V/krpm	25	14	8	51	28	16	92	43	25	244
Back EMF Phase-Phase <sub>RMS</sub>		$K_e$	V/krpm	18	10	6	36	20	12	65	30	17	173
Coil Resistance per Phase	coils @ 25°C ex. cable	R	Ω	1.38	0.43	0.28	1.93	0.57	0.39	3.02	0.74	0.49	6.84
Coil induction per Phase	$l < 0.6lp$	L	mH	2.58	0.83	0.55	4.05	1.29	0.86	7.93	1.75	1.17	25.3
Electrical Time Constant	coils @ 25°C	$\tau_e$	ms	1.9	2.0	1.9	2.1	2.3	2.2	2.6	2.4	2.4	3.7
Poles		$N_{mgn}$	nr	20	20	20	20	20	20	20	20	20	20
Continuous Power Loss	coils @ 100°C	$P_c$	W	115	115	115	214	214	214	300	300	300	469
Thermal Resistance <sup>(3)</sup>	coils to mount. sfc.	$R_{th}$	°C/W	0.65	0.65	0.65	0.35	0.35	0.35	0.25	0.25	0.25	0.16
Thermal Time Constant	Up to 63% max. coiltemp	$\tau_{th}$	s	21	25	25	16	18	18	17	17	17	25
Temperature Cut-off / Sensor				PTC 1kΩ / KTY83-122									
Stator OD		OD <sub>S</sub>	mm	105									
Rotor ID		ID <sub>R</sub>	mm	56									
Motor Height		H <sub>motor</sub>	mm	17			25			34			60
Lamination Stack Height		H <sub>arm</sub>	mm	8			16			24			48
Rotor Inertia		$J_R$	kg*m <sup>2</sup>	8.0E-05			1.5E-04			2.2E-04			4.3E-04
Stator Mass	ex. cables	$M_S$	g	299			472			746			1476
Rotor Mass		$M_R$	g	79			146			218			433
Total Mass	ex. cables	$M_T$	g	378			618			964			1909
Cable Mass	all cables	m	g	63	90	90	63	90	90	63	90	90	95
Cable Type (Power)	length 0.5 m	d	mm (AWG)	6.5 (20)	6.7 (14)	6.7 (14)	6.5 (20)	6.7 (14)	6.7 (14)	6.5 (20)	6.7 (14)	6.7 (14)	9.6 (18)
Cable Type (Sensor)	length 0.5 m	d	mm (AWG)	4.3 (26)									



QTR-A-105 Stator and rotor shown with a height of 17 mm

All specifications ±10%

1. Actual values depend on bus voltage. Please check the T/n diagram in our manual or online simulation tool.
2. These values are only applicable when the mounting surface is at 20°C and the motor is driven at maximum continuous current. If these values differ in your application, please check our simulation tool or manual.
3. R<sub>th</sub> based on radial mounting of stator lamination stack.
4. MAXIMUM allowable speed for QTR-A 105 Series motors is 16.500 rpm. If you plan a high speed application, please contact Tecnotion.
5. Y and Z motor rpm specified at 48Vdc. N motor at 300Vdc.

Mounting instructions and tolerances can be found in the Torque installation manual. Manuals and 3D CAD files can be downloaded from our website.

## STATOR

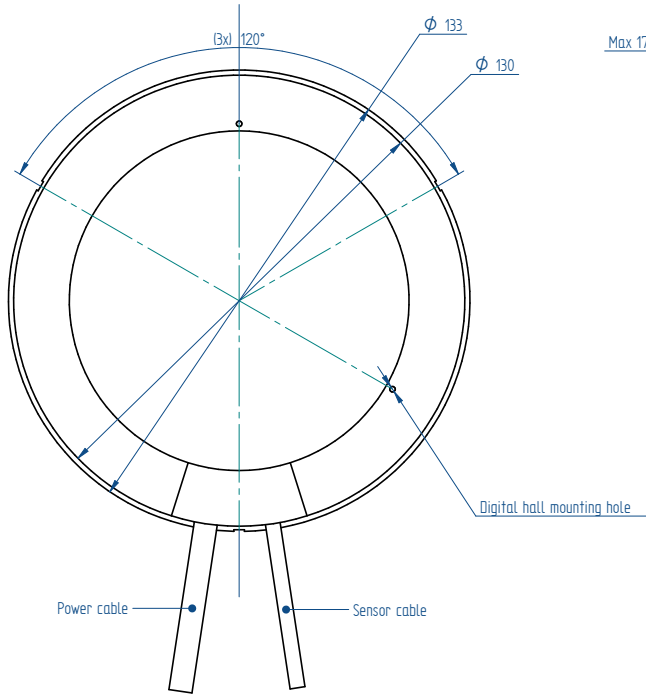

QTR-A-133-17

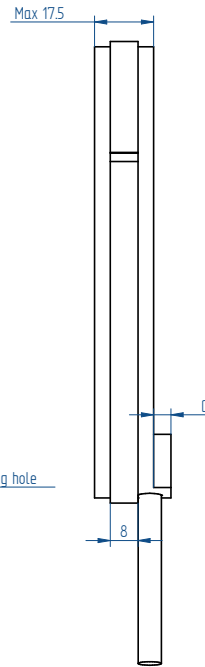

QTR-A-133-25

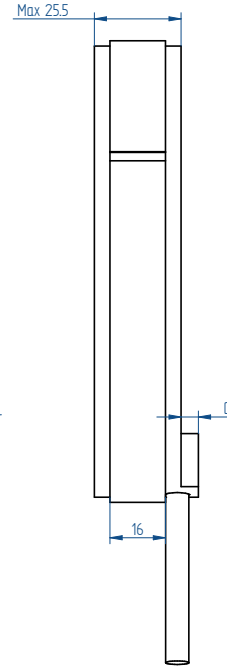

QTR-A-133-34

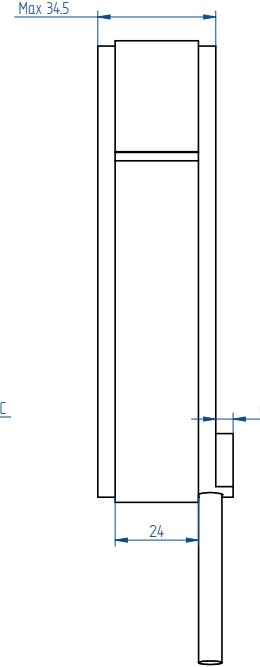

QTR-A-133-60

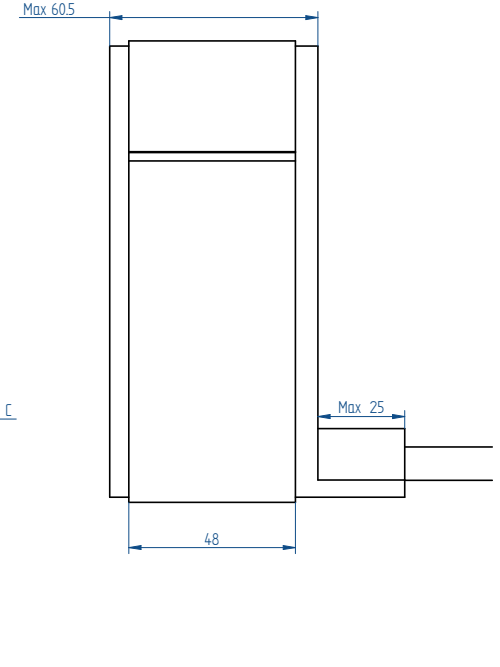

## ROTOR

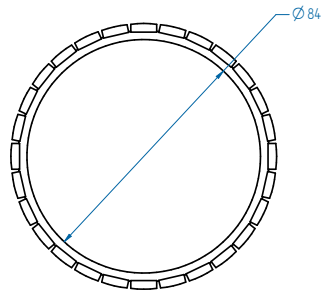

\* All sizes are in mm

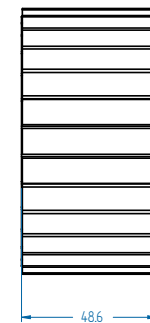
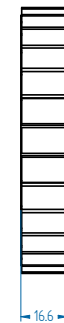
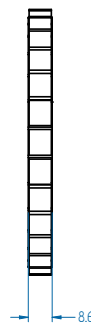

winding	C (mm)
N	3.5
Y+Z	5.5



	Parameter	Remarks	Symbol	Unit	QTR-A-133-17			QTR-A-133-25			QTR-A-133-34		QTR-A-133-60
					N	Y	Z	N	Y	Z	N	Z	N
Performance	Winding type				N	Y	Z	N	Y	Z	N	Z	N
	Motor type, max voltage ph-ph	3-Phase synchronous		$V_{acrms} (V_{dc})$	230 (300)								420 (600)
	Ultimate Torque @ 20°C/s increase	magnet @ 25°C	$T_u$	Nm	5.6	6.4	6.4	11.9	13.5	13.5	20.6	20.3	55.5
	Peak Torque @ 6°C/s increase	magnet @ 25°C	$T_p$	Nm	3.8	4.3	4.3	7.5	8.6	8.6	13.1	12.9	35.3
	Continuous Torque	coil @ 100°C	$T_c$	Nm	2.6	2.6	2.6	5.9	6.0	6.0	10.0	9.5	21.9
	Maximum speed <sup>(1)(4)(5)</sup>	@Tc	$n_{max}$	rpm	3477	779	1547	1779	319	737	910	452	684
	Motor Torque constant	up to I <sub>c</sub>	$K_t$	Nm/A <sub>rms</sub>	0.58	0.33	0.19	1.16	0.65	0.38	2.09	0.56	5.57
	Motor constant	coils @ 25°C	$K_m$	(Nm) <sup>2</sup> /W	0.058	0.061	0.061	0.167	0.177	0.180	0.344	0.310	1.08
	Ultimate Current	magnet @ 70°C	$I_u$	A <sub>rms</sub>	13.8	28.2	48.8	13.8	28.2	48.8	13.3	48.8	13.5
	Peak Current	magnet @ 25°C	$I_p$	A <sub>rms</sub>	7.56	15.40	26.70	7.56	15.40	26.70	7.31	26.70	7.37
Electrical	Maximum Continuous Current <sup>(2)</sup>	coils @ 100°C	$I_c$	A <sub>rms</sub>	4.43	8.10	14.00	5.05	9.30	16.10	4.77	16.90	3.93
	Back EMF Phase-Phase <sub>peak</sub>		$K_e$	V/krpm	50	28	16	99	56	32	179	48	476
	Back EMF Phase-Phase <sub>rms</sub>		$K_e$	V/krpm	35	20	11	70	39	23	126	34	337
	Coil Resistance per Phase	coils @ 25°C ex. cable	R	Ω	1.93	0.58	0.39	2.70	0.80	0.54	4.23	0.68	9.58
	Coil induction per Phase	l < 0.6 lp	L	mH	3.74	1.20	0.80	5.87	1.87	1.25	11.50	1.69	36.6
	Electrical Time Constant	coils @ 25°C	$\tau_e$	ms	1.9	2.1	2.0	2.2	2.4	2.3	2.7	2.5	3.8
	Poles		$N_{mgn}$	nr	28	28	28	28	28	28	28	28	28
Thermal	Continuous Power Loss	coils @ 100°C	$P_c$	W	147	147	147	268	268	268	375	375	577
	Thermal Resistance <sup>(3)</sup>	coils to mount. sfc.	$R_{th}$	°C/W	0.51	0.51	0.51	0.28	0.28	0.28	0.20	0.20	0.13
	Thermal Time Constant	Up to 63% max. coiltemp	$\tau_{th}$	s	23	27	27	18	21	21	19	19	29
	Temperature Cut-off / Sensor				PTC 1kΩ / KTY83-122								
Mechanical	Stator OD		OD <sub>s</sub>	mm	133								
	Rotor ID		ID <sub>r</sub>	mm	84								
	Motor Height		H <sub>motor</sub>	mm	17			25			34		60
	Lamination Stack Height		H <sub>arm</sub>	mm	8			16			24		48
	Rotor Inertia		J <sub>r</sub>	kg*m <sup>2</sup>	2.1E-04			4.2E-04			6.2E-04		1.2E-03
	Stator Mass	ex. cables	M <sub>s</sub>	g	414			717			1037		2090
	Rotor Mass		M <sub>r</sub>	g	106			208			309		613
	Total Mass	ex. cables	M <sub>t</sub>	g	520			925			1346		2703
	Cable Mass	all cables	m	g	63	90	90	63	90	90	63	90	95
	Cable Type (Power)	length 0.5 m	d	mm (AWG)	6.5 (20)	6.7 (14)	6.7 (14)	6.5 (20)	6.7 (14)	6.7 (14)	6.5 (20)	6.7 (14)	9.6 (18)
Cable Type (Sensor)	length 0.5 m	d	mm (AWG)	4.3 (26)									



QTR-A-133 Stator and rotor shown with a height of 17 mm

All specifications ±10%

- Actual values depend on bus voltage. Please check the T/n diagram in our manual or online simulation tool.
- These values are only applicable when the mounting surface is at 20°C and the motor is driven at maximum continuous current. If these values differ in your application, please check our simulation tool or manual.
- R<sub>th</sub> based on radial mounting of stator lamination stack.
- MAXIMUM allowable speed for QTR-A 133 Series motors is 14,000 rpm. If you plan a high speed application, please contact Tecnotion.
- Y and Z motor rpm specified at 48Vdc. N motor at 300Vdc.

Mounting instructions and tolerances can be found in the Torque installation manual. Manuals and 3D CAD files can be downloaded from our website.

## STATOR

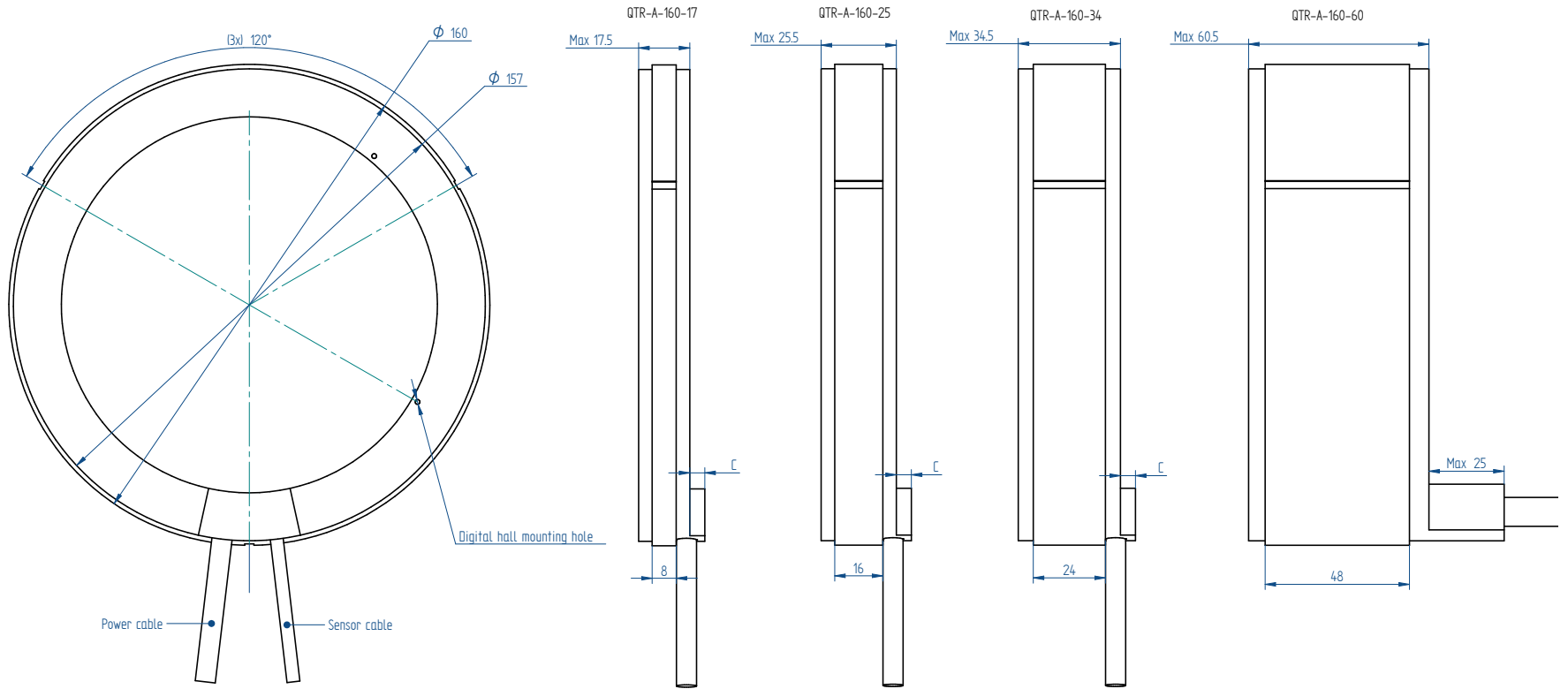

## ROTOR

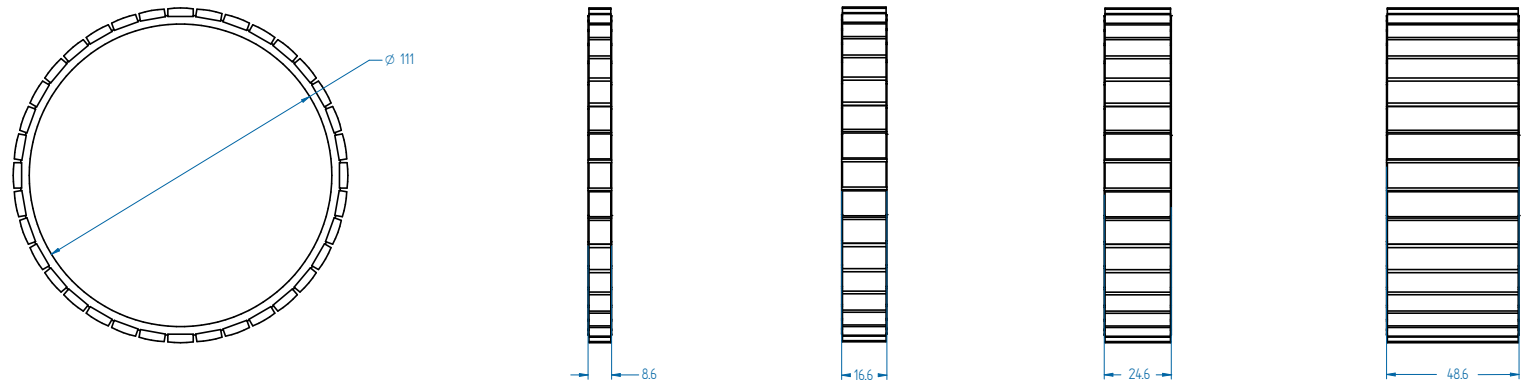

\* All sizes are in mm

winding	C (mm)
N	3.5
Y+Z	5.5

Parameter	Remarks	Symbol	Unit	QTR-A-160-17			QTR-A-160-25			QTR-A-160-34		QTR-A-160-60
Winding type				N	Y	Z	N	Y	Z	N	Z	N
Motor type, max voltage ph-ph	3-Phase synchronous		$V_{acrms} (V_{dc})$	230 (300)								420 (600)
Ultimate Torque @ 20°C/s increase	magnet @ 25°C	$T_u$	Nm	9.3	10.6	10.6	19.6	22.4	22.4	34.1	33.6	91.6
Peak Torque @ 6°C/s increase	magnet @ 25°C	$T_p$	Nm	6.2	7.1	7.1	12.5	14.2	14.2	21.7	21.4	58.3
Continuous Torque	coil @ 100°C	$T_c$	Nm	4.1	4.2	4.2	9.4	9.7	9.7	15.7	15.0	36.3
Maximum speed <sup>(1)(4)(5)</sup>	@Tc	$n_{max}$	rpm	2095	434	919	1042	149	413	526	239	385
Motor Torque constant	up to I <sub>c</sub>	$K_t$	Nm/A <sub>rms</sub>	0.96	0.54	0.31	1.92	1.07	0.62	3.45	0.93	9.20
Motor constant	coils @ 25°C	$K_m$	(Nm) <sup>2</sup> /W	0.12	0.13	0.13	0.35	0.38	0.38	0.73	0.67	2.29
Ultimate Current	magnet @ 70°C	$I_u$	A <sub>rms</sub>	13.8	28.2	48.8	13.8	28.2	48.8	13.3	48.8	13.5
Peak Current	magnet @ 25°C	$I_p$	A <sub>rms</sub>	7.6	15.4	26.7	7.6	15.4	26.7	7.3	26.7	7.4
Maximum Continuous Current <sup>(2)</sup>	coils @ 100°C	$I_c$	A <sub>rms</sub>	4.3	7.8	13.4	4.9	9.0	15.7	4.6	16.2	3.9
Back EMF Phase-Phase <sub>peak</sub>		$K_e$	V/krpm	82	46	26	164	92	53	295	79	787
Back EMF Phase-Phase <sub>rms</sub>		$K_e$	V/krpm	58	32	19	116	65	37	209	56	556
Coil Resistance per Phase	coils @ 25°C ex. cable	R	Ω	2.47	0.75	0.50	3.47	1.03	0.69	5.45	0.87	12.30
Coil induction per Phase	l < 0.6 lp	L	mH	4.89	1.57	1.04	7.68	2.45	1.63	15.0	2.21	47.9
Electrical Time Constant	coils @ 25°C	$\tau_e$	ms	2.0	2.1	2.1	2.2	2.4	2.4	2.8	2.5	3.9
Poles		$N_{mgn}$	nr	36	36	36	36	36	36	36	36	36
Continuous Power Loss	coils @ 100°C	$P_c$	W	174	174	174	326	326	326	441	441	750
Thermal Resistance <sup>(3)</sup>	coils to mount. sfc.	$R_{th}$	°C/W	0.43	0.43	0.43	0.23	0.23	0.23	0.17	0.17	0.10
Thermal Time Constant	Up to 63% max. coiltemp	$\tau_{th}$	s	25	29	29	19	22	22	21	21	29
Temperature Cut-off / Sensor				PTC 1kΩ / KTY83-122								
Stator OD		OD <sub>s</sub>	mm	160								
Rotor ID		ID <sub>r</sub>	mm	111								
Motor Height		H <sub>motor</sub>	mm	17			25			34		60
Lamination Stack Height		H <sub>arm</sub>	mm	8			16			24		48
Rotor Inertia		$J_r$	kg*m <sup>2</sup>	4.7E-04			9.2E-04			1.4E-03		2.6E-03
Stator Mass	ex. cables	$M_s$	g	527			875			1212		2555
Rotor Mass		$M_r$	g	138			269			401		754
Total Mass	ex. cables	$M_T$	g	665			1144			1613		3309
Cable Mass	all cables	m	g	63	90	90	63	90	90	63	90	95
Cable Type (Power)	length 0.5 m	d	mm (AWG)	6.5 (20)	6.7 (14)	6.7 (14)	6.5 (20)	6.7 (14)	6.7 (14)	6.5 (20)	6.7 (14)	9.6 (18)
Cable Type (Sensor)	length 0.5 m	d	mm (AWG)	4.3 (26)								



QTR-A-160 Stator and rotor shown with a height of 17 mm

All specifications ±10%

1. Actual values depend on bus voltage. Please check the T/n diagram in our manual or online simulation tool.
2. These values are only applicable when the mounting surface is at 20°C and the motor is driven at maximum continuous current. If these values differ in your application, please check our simulation tool or manual.
3. R<sub>th</sub> based on radial mounting of stator lamination stack.
4. MAXIMUM allowable speed for QTR-A 160 Series motors is 12,000 rpm. If you plan a high speed application, please contact Tecnotion.
5. Y and Z motor rpm specified at 48Vdc, N motor at 300Vdc.

## Why choose Tecnotion's Torque motor series?

Tecnotion's QTR torque motor series can find its way into many different markets, for example semiconductor, robotics, packaging, printing, machine tooling or medical application markets.

Due to the extensive motor design knowledge within Tecnotion, the QTR series are ahead in development. Compared to other torque motors, the QTR series offers a superior torque density and stands out with its small size and low weight. The QTR has a low build height and large inner diameter while offering the same or higher torque specifications compared to other torque motors. The low motor mass provides the opportunity to improve entire stage designs, offering great opportunities to lower total

cost of ownership in an application. Tecnotion's extensive experience in coil design also reflects in the QTR thermal resistance characteristics. The QTR series offers enhanced thermal management compared to competitors. This can contribute, for instance, to motor reliability.

Finally, the QTR series also has a low cogging value like Tecnotion's iron core motor series, offering a smooth running characteristic and excellent position accuracy.

### The range

The torque range consists of a series of five different outer diameters: 65, 78, 105, 133 and 160 mm for the largest motor. Each series has four build heights ranging from 17 mm up to 60 mm.



## Additional products

To download our CAD files, installation manuals, product specifications and more, visit our website at:

[www.tecnotion.com](http://www.tecnotion.com)

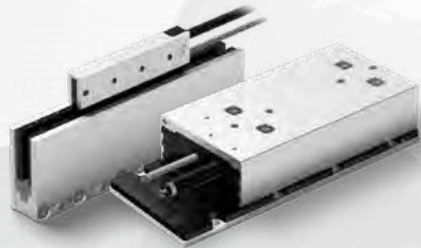

### Product Series

#### *Iron Core & Ironless Motor Series*

Tecnotions linear motor series rely on 25 years of linear motor development experience. All motors excel in their force density ratings. They offer continuous force in a range of 10 Newton to 3000 Newton in a surprisingly small package.

Tecnotion can provide linear solutions for most applications which require a strong iron core linear motor or a highly dynamic ironless type linear motor.

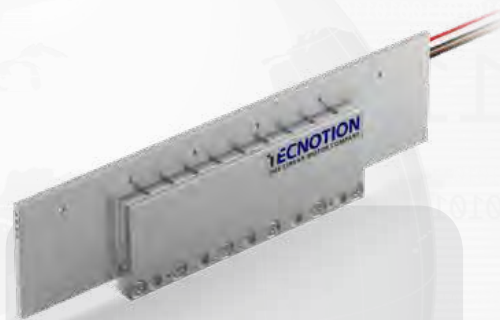

### Vacuum Series

#### *Outgassing down to 10<sup>-8</sup> mbar*

Many years of experience is used in designing and building vacuum coils and magnets. Tecnotion can supply any vacuum linear motor that can match even the strictest vacuum requirements, for instance in the semiconductor industry.

Our vacuum rated ironless linear motors are a specifically designed coil units and magnet yokes for use in high- vacuum, down to 10<sup>-8</sup> mBar.



### Simulation Tool

#### *Analyze your application*

Save precious time by using our FREE Torque motor simulation tool. Our specialized software helps you find the best motor for the application and generate reports within seconds, without having to make time consuming calculations by hand.

The tool will provide you with diagrams for position, velocity, acceleration, jerk, torque, power, voltage, current, temperature, torque vs. velocity and more. Find the simulation tool at [www.tecnotion.com/simtool](http://www.tecnotion.com/simtool).



### Custom Motors

#### *Motor solutions*

Besides the standard catalogue items we offer custom linear motor solutions. Some examples: custom windings, cable confection and vacuum motors for transport and positioning in vacuum.

Besides this Tecnotion offers moving magnet motors and linear actuators, completely designed toward needs. For more information please contact Tecnotion.

## Article numbers

Series	Article	Article code
QTR	TORQUE KIT QTR-A-65-17 N	10 8062
QTR	TORQUE KIT QTR-A-65-25 N	10 8393
QTR	TORQUE KIT QTR-A-65-34 Y	10 8394
QTR	TORQUE KIT QTR-A-65-60 Y	10 8395
QTR	TORQUE KIT QTR-A-78-17 N	10 8397
QTR	TORQUE KIT QTR-A-78-25 Y	10 8399
QTR	TORQUE KIT QTR-A-78-34 Y	10 8400
QTR	TORQUE KIT QTR-A-78-60 Y	10 8401
QTR	TORQUE KIT QTR-A-105-17-N	4022 368 6120
QTR	TORQUE KIT QTR-A-105-17-Y	10 8848
QTR	TORQUE KIT QTR-A-105-17-Z	10 8158
QTR	TORQUE KIT QTR-A-105-25-N	4022 368 6121
QTR	TORQUE KIT QTR-A-105-34-N	4022 368 6122
QTR	TORQUE KIT QTR-A-105-60-N	4022 368 6123
QTR	TORQUE KIT QTR-A-133-17-N	4022 368 6140
QTR	TORQUE KIT QTR-A-133-25-N	4022 368 6141
QTR	TORQUE KIT QTR-A-133-25-Z	10 8159
QTR	TORQUE KIT QTR-A-133-34-N	4022 368 6142
QTR	TORQUE KIT QTR-A-133-60-N	4022 368 6143
QTR	TORQUE KIT QTR-A-160-17-N	4022 368 6160
QTR	TORQUE KIT QTR-A-160-17-Y	4022 368 5589
QTR	TORQUE KIT QTR-A-160-25-N	4022 368 6161
QTR	TORQUE KIT QTR-A-160-34-N	4022 368 6162
QTR	TORQUE KIT QTR-A-160-34-Z	10 8160
QTR	TORQUE KIT QTR-A-160-60-N	4022 368 6163
QTR	DIGITAL HALL MODULE QTR 105	10 8233
QTR	DIGITAL HALL MODULE QTR 133	10 8234
QTR	DIGITAL HALL MODULE QTR 160	10 8235



This catalogue is offered to you by:



[800-433-3434](tel:800-433-3434) [info@grp6.com](mailto:info@grp6.com)

**Tecnotion Headquarters**

Twentepoort West 15  
7609 RD Almelo  
The Netherlands

Tel. +31 (0)546 536 300  
Fax +31 (0)546 536 380  
[sales@tecnotion.com](mailto:sales@tecnotion.com)

**Tecnotion GmbH**

Elsenheimerstraße 59  
80687 München  
Deutschland

Tel. +49 89 381537-400  
Fax +49 89 381537-409  
[info@tecnotion.de](mailto:info@tecnotion.de)

**Tecnotion Poland**

Ul. Ryżowa 49  
02-495 Warszawa  
Poland

Tel. +48 606 544 046  
[info@tecnotion.pl](mailto:info@tecnotion.pl)

**Tecnotion Rep. of Korea**

Room #409,  
Seoul forest Halla Echo Valley  
25, Ttukseom-ro 1-gil  
04778 Seongdong-gu,  
Seoul South Korea

Tel. +82 (0)10 4540 5599  
[korea@tecnotion.com](mailto:korea@tecnotion.com)

Email: [info@grp6.com](mailto:info@grp6.com) Tel: 800-433-3434 x110